



4KS

More robust. Stronger. More secure.





4KS. More robust. Stronger. More secure

You can always rely on 4KS. Thanks to its high level of resilience, the system also locks and unlocks in the toughest conditions. Even after years, it works like on the first day. This makes 4KS your first choice for the toughest conditions – at high altitudes or in production facilities subject to high amounts of dirt. And not just that. 4KS also offers extensive expansion capabilities, which enables the implementation of highly complex locking systems.



The benefits of 4KS at a glance

- › Resilient and extremely durable
 - › For master key systems with a highly complex structure
 - › Springless technology
 - › Patent protection until 2037 at the latest*
-

The access system for highly complex structured master key systems

4KS is ideal for locking systems with a complex structure and a large number of different user groups. Such as universities, shopping centres, retail chains and industrial companies. In cooperation with qualified partners, EVVA has been providing security technology for a hundred years.



Vienna University | Austria

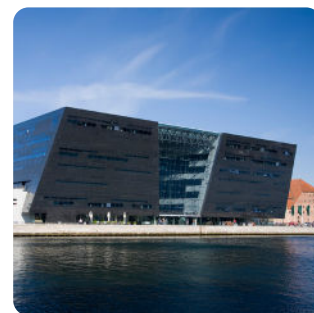

Royal Library | DK

4KS. One system, many details

Unlike other locking systems, the locking elements in the 4KS cylinder move along the curves on the key. A total of 12 springless, massive locking pins are brought into a specific position via positive control of the six key curves and scanned by two control bars. As a result of the key's overlapping curve milling it is virtually tamper-proof.

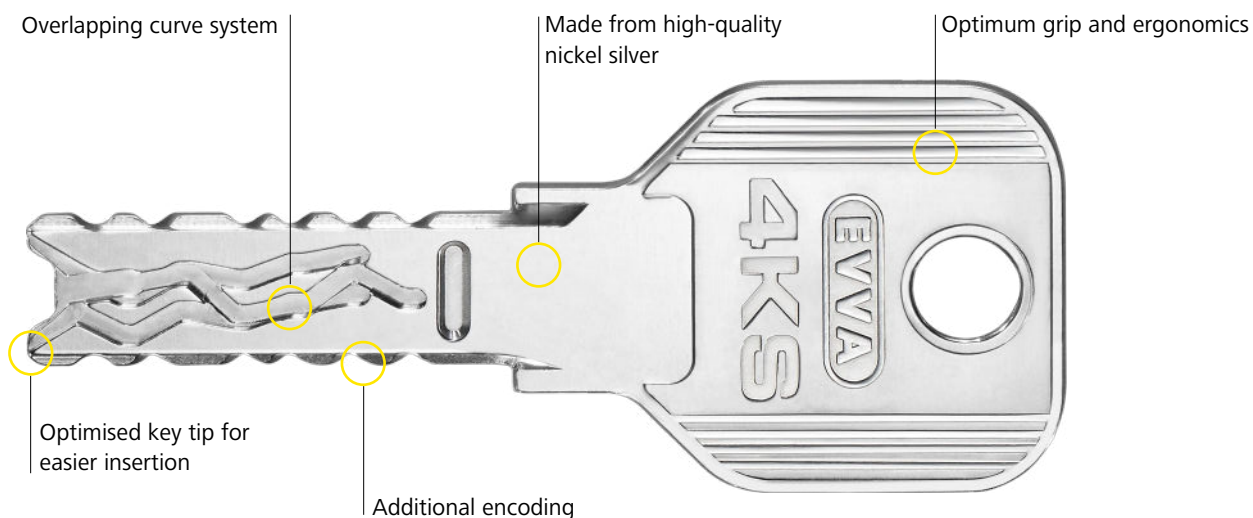

Practical, handy and appealing.

Optionally, 4KS keys are available in a range of colours. The colour coding helps to easily distinguish between keys.



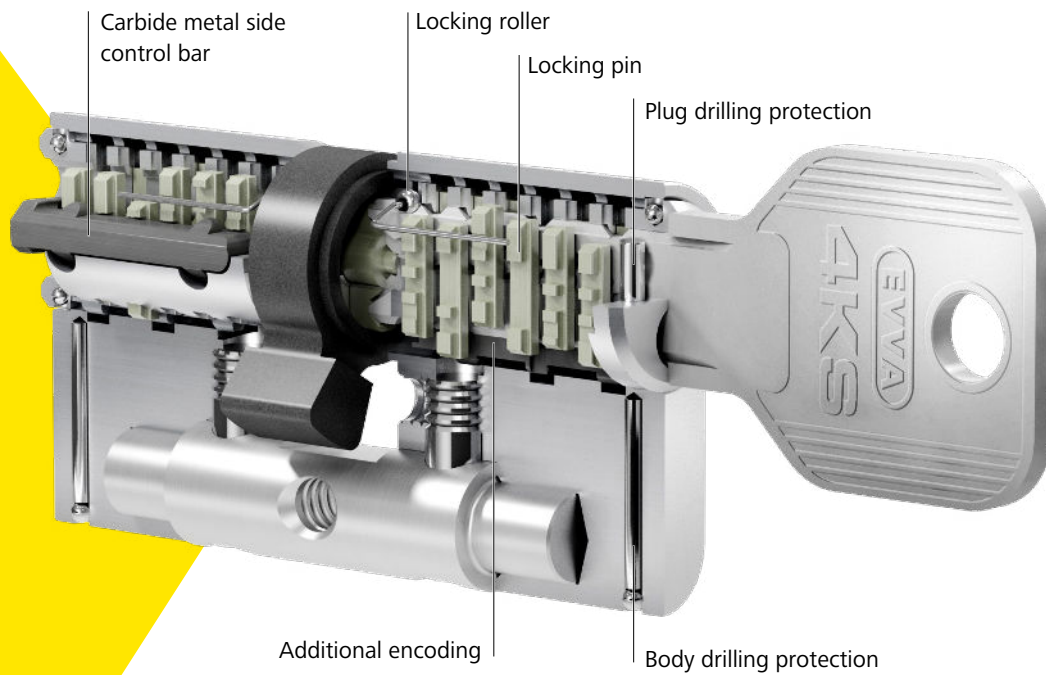

All-round protection:

Copy keys, additional cylinders and locking charts are available from authorised EVVA Partners and only with corresponding proof of legitimacy, EVVA security cards.

Benefit from the security features

The reliable technology of the 4KS cylinder offers lasting protection against illegal opening methods:



Drilling protection



Plug pulling protection



4KS. Plan view

Due to their features, numerous variants and options, 4KS cylinder locks can handle all access situations which a master key system may meet.

Thus, access to rooms and storeys, access to cabinets and showcases or the activation of barriers or other electronic equipment can be clearly structured. This means even more comfort and more security.



Switch cylinder

operate control elements such as in lift systems.



Double cylinder

are suitable for indoors and outdoors and can be configured with a number of variants and options.



Half cylinder

are suitable for barriers, key switches, lifts and numerous other situations.

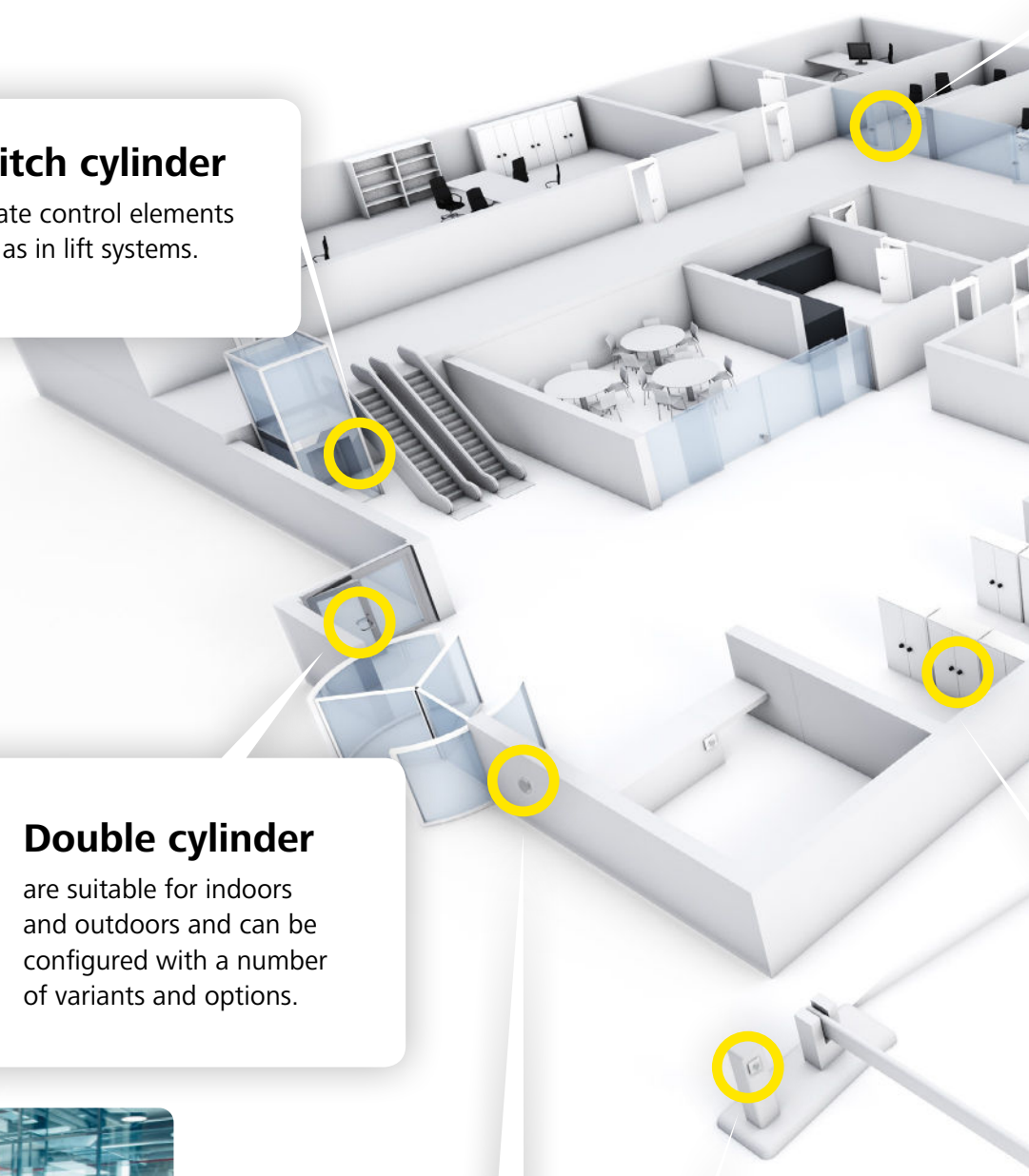



Thumb turn cylinder

enables convenient opening and closing without keys.

The right cylinder for every situation



Cam locks

for letter boxes and secure storage in showcases and cabinets.



Switch cylinder with integrated micro-switch

as machine switch or on control panels for electronic systems.



Padlock

efficiently integrate external objects into the locking system



Furniture cylinder

ensure secure storage of important documents.

4KS. Master key systems and structure

EVVA and its project partners have been creating and developing lock charts since almost 100 years, using its extensive know-how to achieve great success.



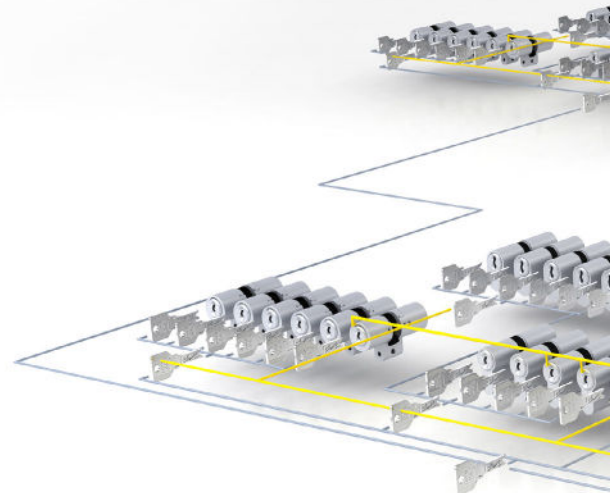



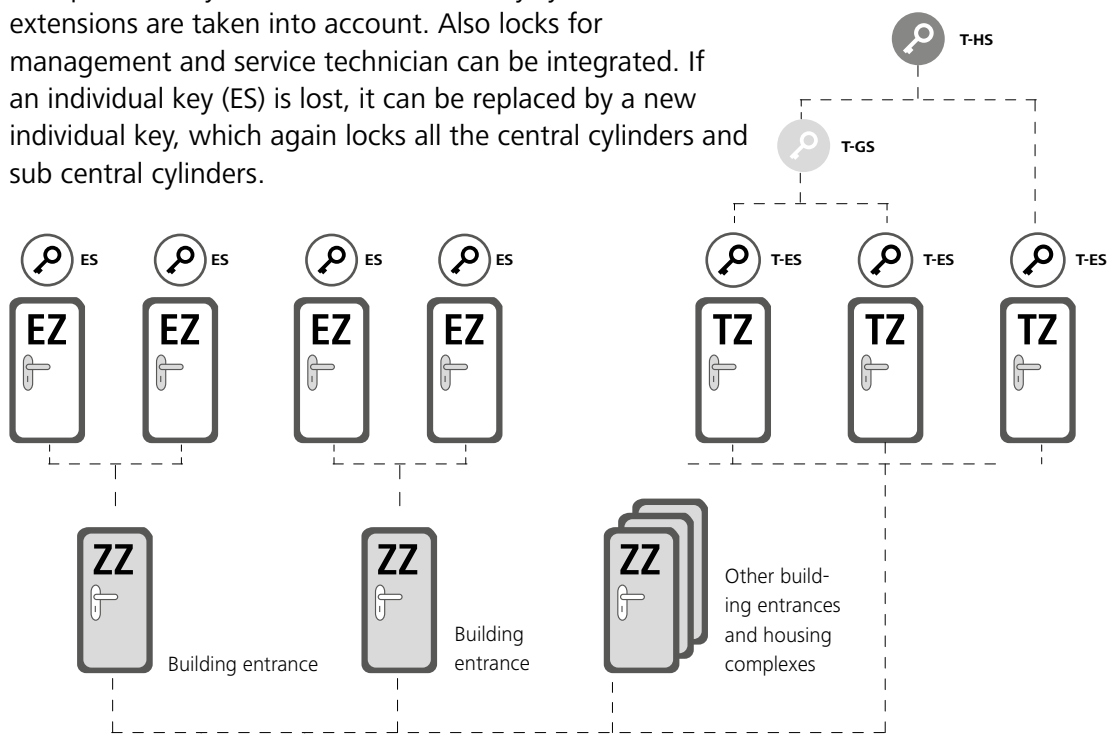

4KS is particularly suitable for highly complex master key system structures due to its extensive expansion capabilities. With its coding characteristics such as length profile, curve scanning and internal scanning elements, exceptions in the locking hierarchy can also be taken into account.



Example of an residential complex

For apartment cylinders, future master key system extensions are taken into account. Also locks for management and service technician can be integrated. If an individual key (ES) is lost, it can be replaced by a new individual key, which again locks all the central cylinders and sub central cylinders.



-  **T-HS** | Technical master key
-  **T-GS** | Technical group key
-  **T-ES** | Technical individual key
-  **ES** | Individual key
-  **GZ** | Complete central cylinder
-  **ZZ** | Central cylinder
-  **EZ** | Apartment door cylinder
-  **TZ** | Engineering room cylinder



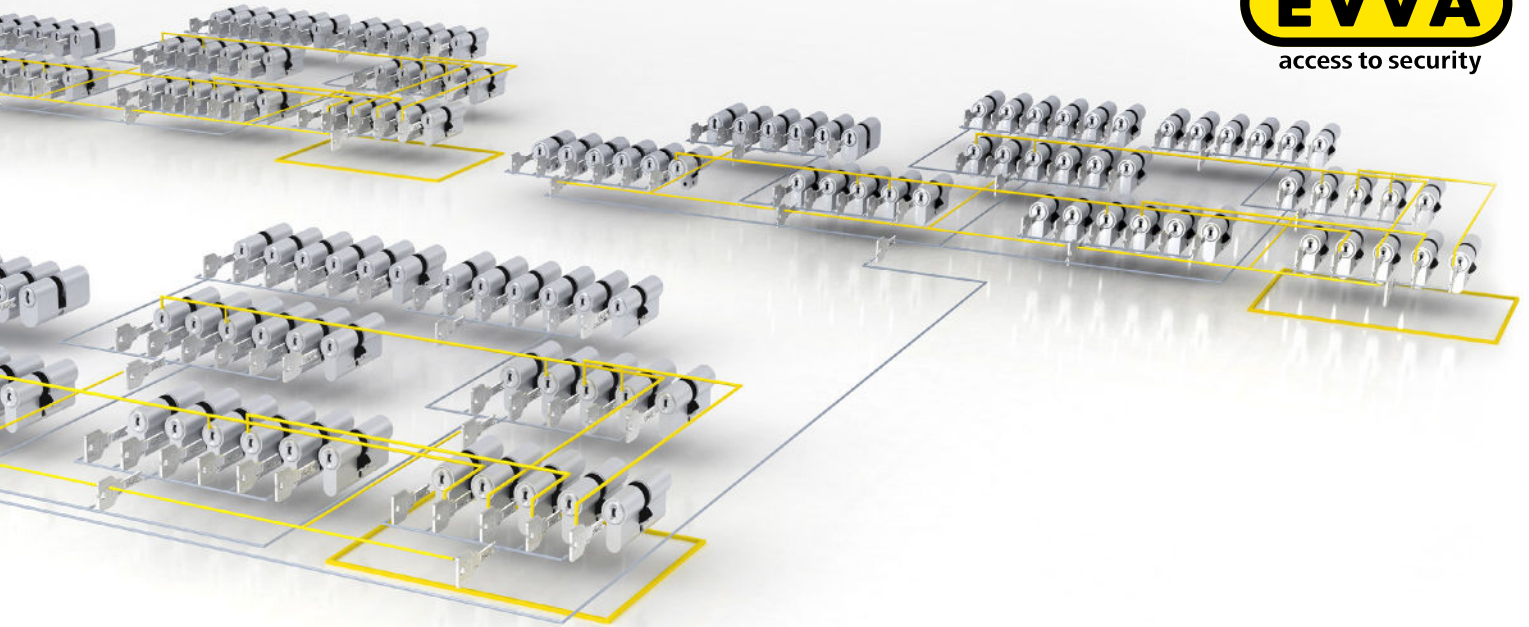





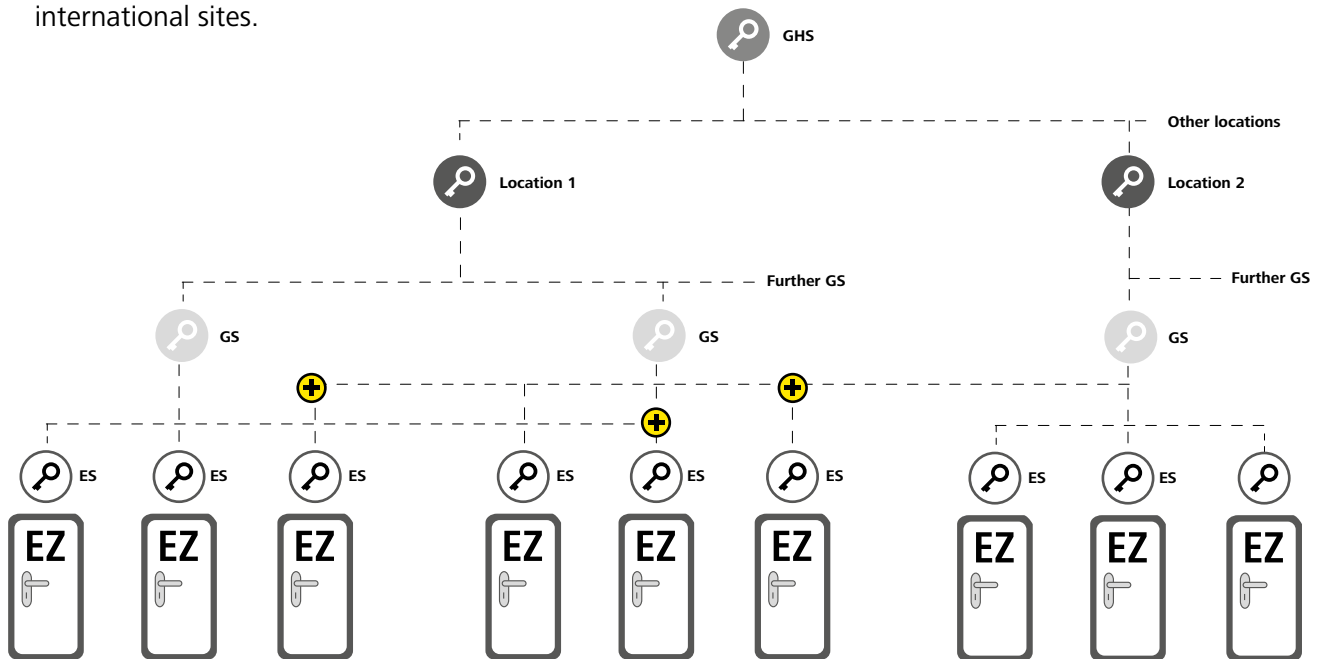

Example business premises

Grand master key system with highly complex structure. With forward-looking planning, 4KS simply grows with your business success. Suitable for distributed locations and international sites.



-  **GHS** | Grand master key
-  **HGS** | Sub master key
-  **GS** | Group key
-  **ES** | Individual key
-  Individual cylinder
-  Special authorisation



Unique EVVA service

Since 1919, EVVA services have been geared towards customer benefits. This has resulted in products adapted to the market, the best product and consulting service for customers and partners as well as a locking system expertise that boosts customer convenience and gives operators a competitive, economic edge.



Master key systems from professionals

Master key systems define who has access to which facilities. EVVA provides comprehensive expertise in planning master key systems and electronic access control systems. The company's range also includes the calculation of high-performance locking systems with complex authorisation structures.



Your EVVA Partner portal

Our Partner portal provides everything you as EVVA Partners need as part of your everyday activities: Price lists, catalogues, data sheets and the option to sign up to training sessions.



Mechanical and electronic systems

EVVA is one of the leading manufacturers that develops and produces electronic and mechanical locking systems in Vienna. EVVA's electronic and mechanical products can be combined in locking systems around the world depending on customer demands.



Excellent advice

EVVA is your reliable partner. Be it for technical queries concerning EVVA products or planning issues regarding a project, you can always count on EVVA.

Innovation made in Austria

Trust a family-owned business that has been researching, developing and producing for 100 years and operates in a respectful and cooperative way. EVVA – Leading European manufacturer in mechanical and electronic locking systems!

www.evva.com